

MecALAC

15MWR



15MWR

MecALAC





**15MWR**

## **URBAN MACHINE HUMAN ENGINE**

*“For the past 60 years, innovation, accuracy and the search for performance have been the leading keywords of our company’s vision. At Mecalac, we imagine the machines designed for the construction sites of the 21st century. Since every job has its own characteristics and restrictions, since each country has its own culture, we build machines that respond perfectly to today’s challenges. Our machines are created by men, for men! We are proud to be human innovators who improve and push back the limits of our clients’ objectives.”*

Henri Marchetta, Chairman  
Groupe Mecalac S.A.S.



**15MWR**

# A NEW REFERENCE

**A NEW STANDARD  
IS BORN BASED  
UPON  
COMPACTNESS  
AND MOBILITY**



Joining such a level of compactness with the mobility of a four-wheel drive frame is simply revolutionary.





**WATCH THE DEMO**

**MECALAC INNOVATES  
AND OFFERS YOU TO  
WATCH MWR VIDEOS.**

It's easy, all you need to do is scan the QR codes present on the pages of the brochure with your smartphone in order to access the video content.

If you don't have a scanning app, you can download a QR code scanner from the App Store or Google Play.





# 15 MWR

## THE SECRET TO STABILITY

### DESIGN: A STRONG AND STRATEGIC COMPONENT OF THE MECALAC IDENTITY

*“Our strength? Offering each client the most efficient solution. A deep analysis of users’ work process allows us to provide the right industrial and versatile answer to their requests. This approach allows to offer better fitted machines based on the real needs of the jobsite. At Mecalac, design has always been part of our creation process. It is a strong and strategic component of our brand identity and products and is not limited to mere aesthetics. Our design is functional and secure. It blends ergonomics with smooth flowing lines”.*

*Patrick Brehmer,  
Head of Marketing,  
Product Management & Design*

**The complete integration of the counterweight and of the equipment inside the frame print have enabled to combine compactness and stability.**





**THE SECRET TO  
STABILITY LIES IN THE  
INTEGRATION AND  
THE LOWERING OF  
THE MOTOR ON THE  
TURRET.**





**15MWR**

# USER FRIENDLY

**Optimize security for  
the operator as for the  
workers' team of both  
urban and suburban  
construction sites:**

- maintenance feet on the ground
- oscillation locking by the brake pedal and the joystick
- reduced access height
- excellent compactness
- optional integrated and automated cameras
- excellent visibility







USER-FRIENDLY

# DRIVING USER-FRIENDLINESS

## **PARKING, WORK OR ROAD MODE, IN ONE SINGLE SWITCH.**

*Thanks to the unique central selector, the driver can switch into road or parking mode in a single movement, thus sparing 7 to 10 manipulations. With this unique global exclusivity, everything can be done instantly by selecting the desired configuration.*

With this unique, worldwide exclusive function, everything can be done instantly by selecting the desired configuration. This guarantees faultless and ultra-safe driving on construction sites, leaving the driver free to calmly focus on the tasks at hand and take full control of the machine.



↓  
**1 BUTTON**  
3 MODES





USER-FRIENDLY

# CONNECT 'ATTACHED' TO VERSATILITY

**IN ORDER TO MAKE ITS MACHINES  
EVER SAFER AND MORE VERSATILE,  
MECALAC INTRODUCES CONNECT,  
ITS PATENTED QUICK COUPLER,  
NOTABLE FOR ITS LIGHTNESS,  
INTEGRATION, USER-  
FRIENDLINESS, REVERSABILITY  
AND ITS PERFECT SAFETY.**

Controlled from the cab, there is zero risk of it detaching from the tool either while it is being connected or while in operation. It is equipped with a detection system that alerts the driver if the tool is improperly secured (with visual and audible signals). Not only that, but it is also reversible and has an automatic play compensation function, making the CONNECT quick coupler the ultimate connection between tool and machine!





WATCH THE DEMO







USER-FRIENDLY

# SPACE & PANORAMIC VISION

**ALLROUND VISIBILITY HAS BEEN  
THOUGHT OVER TO OPTIMIZE THE  
OPERATOR'S DIRECT VISION.**

The shape of the rear hood has been redesigned and the rounded window is now in one single piece, for a more open view. The main element of the Mecalac boom moves very far when retracted, which offers a great side visibility. The 2 piece windshield is foldable and the door windows can be opened to be at the forefront of the worksite. Thanks to the view mirrors and the 2 cameras, the cabin offers a new vision to the operator who can stay focused on the worksite environment while managing his machine.









USER-FRIENDLY

# ACCESSIBILITY

## CLIMB UP AND DOWN EASILY

Thanks to its perfectly centered turret, the cabin is easily accessible to the driver, without requiring too much effort or taking any risk. The exclusive Mecalac system of a slide swing door allows for easy opening and closing whether the operator is on the ground or seated in the cab.







USER-FRIENDLY

# FILL UP YOUR TANK EFFORTLESSLY

**THE TANK HAS A CAPACITY OF 220 LITRES AND IS EXTREMELY EASY TO ACCESS SINCE IT IS LOCATED IN THE FRAME, JUST ABOVE THE FOOTBOARD THAT LEADS TO THE CABIN.**

Besides helping lower the centre of gravity, the lower-down position of the tank and its increased capacity also mean that the driver or fleet manager no longer has to carry out any operations at height, nor is there anything in the way when driving the vehicle. With the majority of other excavators still mounting the fuel tank in the upper carriage, filling up a 15MWR is as simple as it is safe. Because daily maintenance should always be risk-free.





**15MWR**

# OPTIMAL PERFORMANCE

The 15MWR machine is equipped with numerous technical characteristics for optimal construction site management on all types of terrain.

- naturally balanced
- all terrain capacity
- manoeuvrability
- agility
- compactness
- lifting power



**MWR**

**M**



## PERFORMANCE

# NATURALLY BALANCED

**THE NEW 15MWR BENEFITS FROM 360° ISO STABILITY: THIS MEANS THE MACHINE'S STABILITY REMAINS THE SAME REGARDLESS OF THE ROTATION ANGLE OF THE UPPER CARRIAGE.**

Lift, place, move, unload... all without moving. The new 15MWR transforms worksite logistics thanks to its incredible stability in any position and on any terrain. Whatever the conditions, it stays balanced both when travelling in transfer operations between sites as well as during work phases. This enables an impressive 360° lifting performance - an extraordinary feature.





PERFORMANCE

# GROUND CLEARANCE

**THE LOWERED CENTER OF GRAVITY HAS ABSOLUTELY NO INCIDENCE ON THE GROUND CLEARANCE HEIGHT, WHICH IS AN EXCLUSIVE 'MADE IN MECALAC' PARADOX.**

Thanks to the lowering of the engine on the turret, the 15MWR offers excellent visibility and compactness uncompromising the machine's mobility (wheel dimensions and axle oscillation).





## PERFORMANCE

# MANŒUVRABILITY & COMPACTNESS

The new 15MWR can be equipped with 4 steering wheels thus allowing you to do a U-turn practically on the spot and effectively overcome all obstacles. The aim: ensuring maximum mobility in narrow spaces.





## AGILITY

*Efficiency of movement*

When the leeway is limited, the 15MWR is a powerful ally. Its perfectly integrated and light offset and its 2-piece boom allow the machine to work outside its pattern.

## MOBILITY

*Best manoeuvrability*

The 3 direction modes enable the 15MWR to get out of any situation.

## COMPACTNESS AT WORK

*in the service of security*

With its 360° rotation and the exceptional angular displacement of the boom, the 15MWR only takes up one lane to carry out its tasks, thus preserving the safety of pedestrians and of car drivers. The well thought out dimensions of the machine are ideal in an urban context.

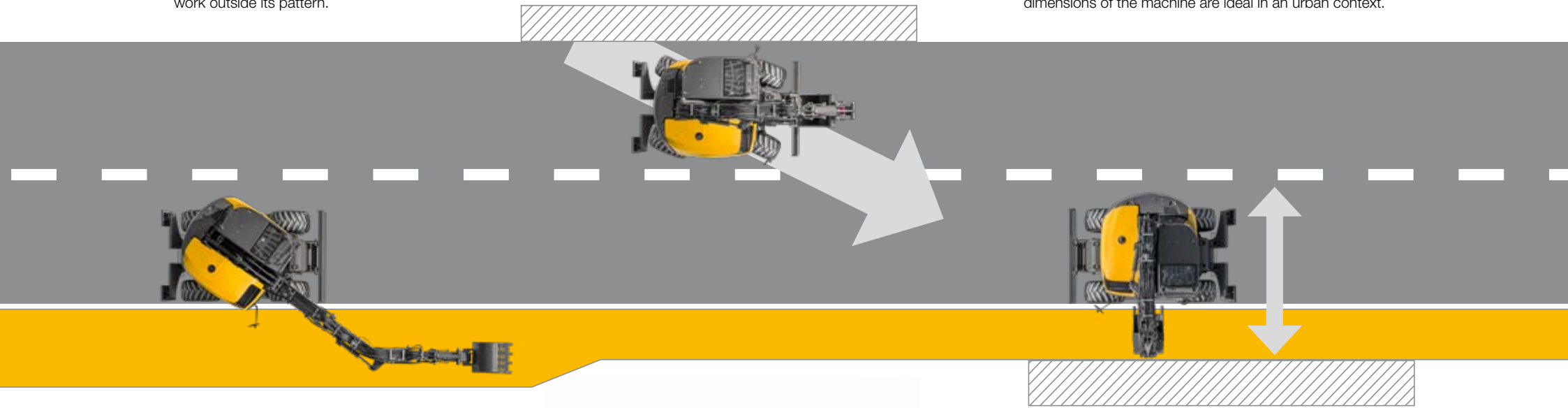

## MAXIMUM COMPACTNESS

*for minimum bulk*

This useful compactness frees 100% performances and 100% functions, therefore reducing the impact of urban construction sites on the environment.

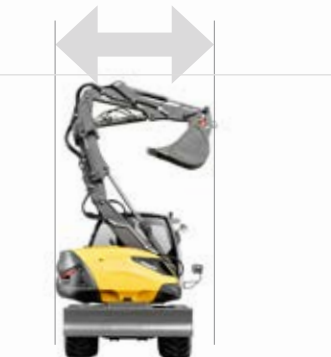



PERFORMANCE

# LIFTING POWER & AMPLITUDE

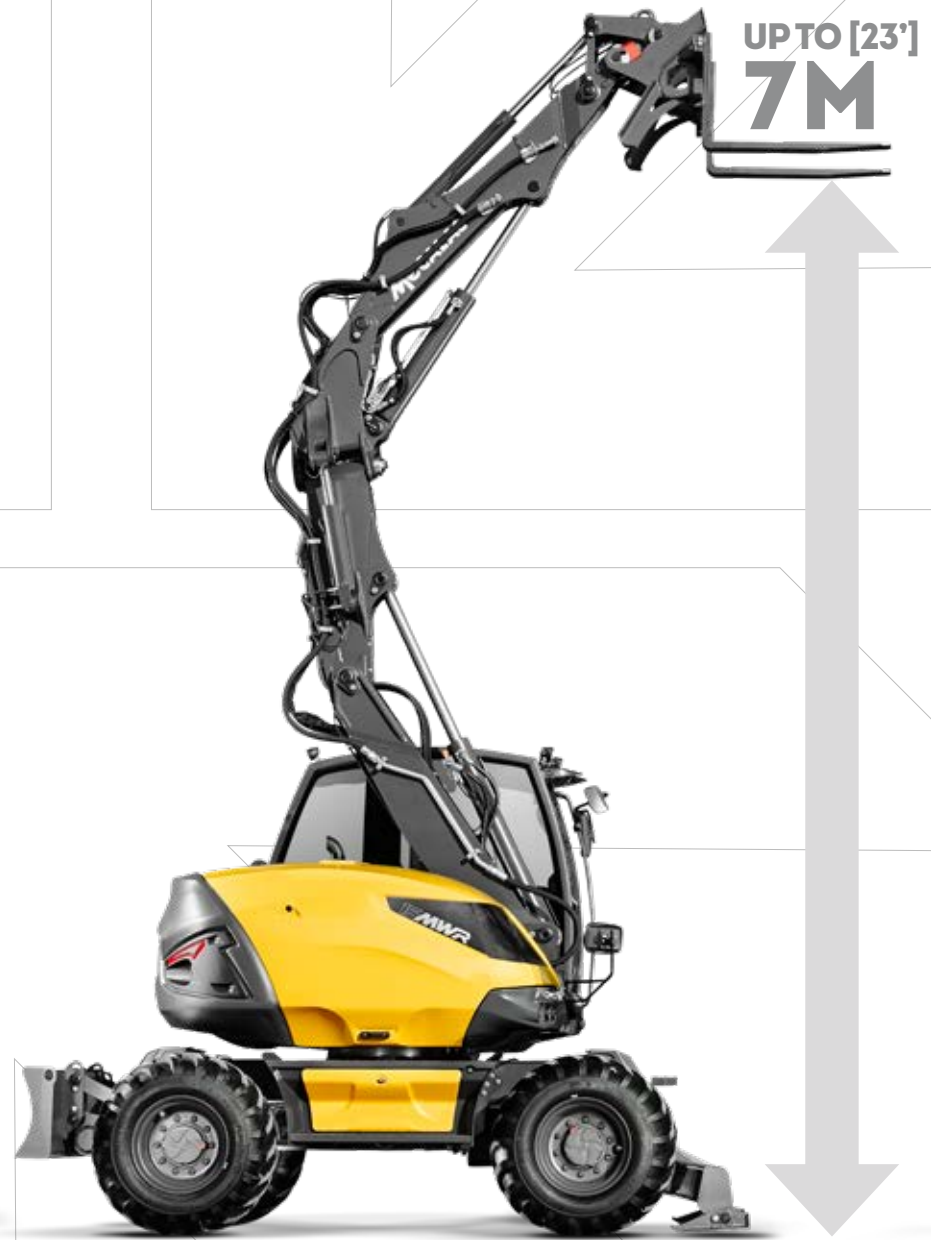

## AN UNRIVALLED COMPACTNESS/LIFTING CAPACITY RATIO:

The unique architecture of the new 15MWR makes this powerful and precise handling machine capable of lifting up to 6.5 tons to 3 meters and 360°!



**360°**



## AMPLITUDE

Equipped with a loader bucket or with pallet forks, the 15MWR allows for an unusual range of amplitude whether up when loading a truck or down when offloading pallets.

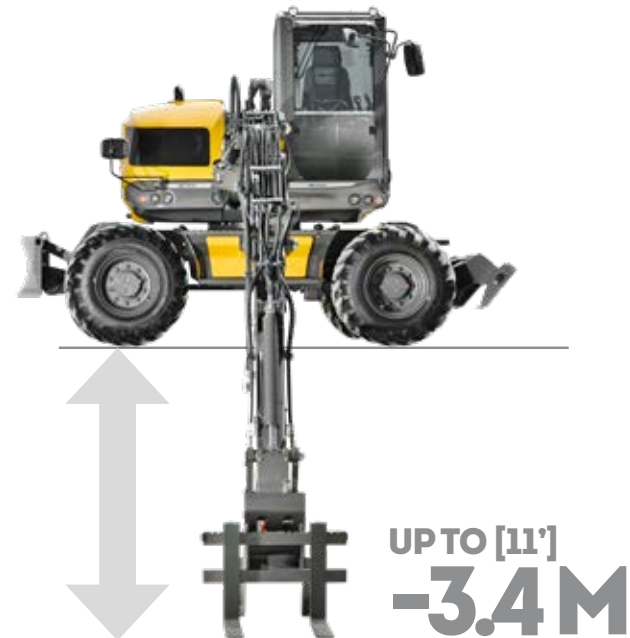



PERFORMANCE

# FROM VERSATILITY TO AUTONOMY

**EXPERTISE IS BORN OF EXPERIENCE.  
OURS IS BASED ON THE STRONG  
CONCEPT THAT PROFITABILITY  
CANNOT BE CONSIDERED WITHOUT  
SIMPLICITY OF USE, COUPLED WITH  
VERSATILITY IN FUNCTIONS.**

No matter the job, the country or the corporate culture, we offer the best visibility, manoeuvrability and freedom on each construction site for optimal autonomy.





**LARGE DIGGING  
AMPLITUDE**

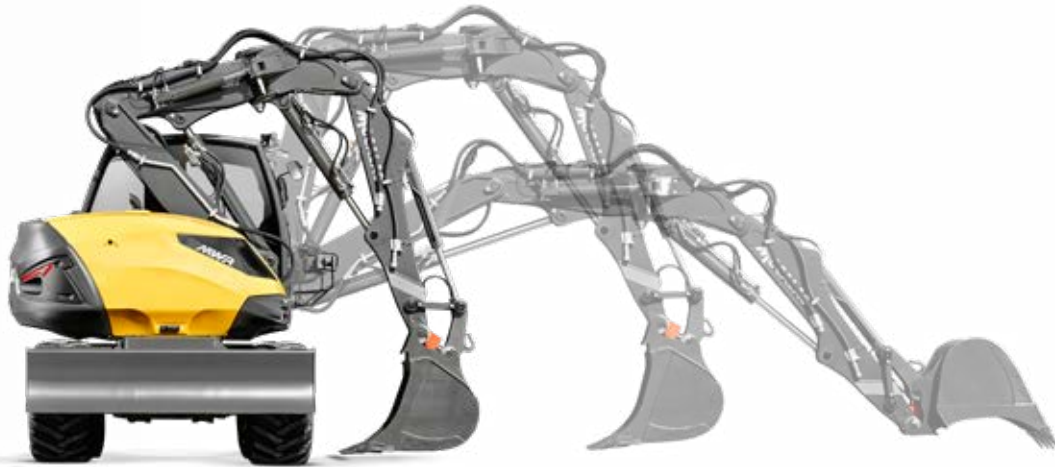

**UNIQUE  
OVERLOADING  
HEIGHT**



**STATIC LOADING**





**15MWR**

# SET UP YOUR MWR

The new 15MWR comes standard equipped with a number of features, while at the same time remaining attentive to the specifications required by various types of customers: landscape and earthwork contractors, public works' professionals, municipal authorities, etc. So, from the color scheme to the choice of tires, heating/AC or cameras, not to mention the various attachments, buckets and hydraulic tools which can be used, there are many different ways to tailor your new 15MWR to your brand and business.



## CUSTOM COLORS

You wish to get your MWR with your brand colors?  
Customize your Mecalac with your own RAL color codes.

Color examples



## TIRES CHOICES

Simple MITAS 18-19.5 (standard)  
Simple MICHELIN XF 18R19.5  
Twin MITAS 10.00-20 16PR NB38 (with spacer)  
Twin CALIBER 315/70 R22.5 (with spacer)  
Large ALLIANCE 600/40-22.5

Standard and optional equipment may vary.  
Consult your Mecalac dealer for details.



## CAB - COMFORT AND SAFETY

Overload warning alarm  
Air conditioning (standard)  
Rotating beacon  
LED rotating beacon  
Travel alarm (standard)  
White noise type adaptative travel alarm  
Additional front working light, LED  
Rear working light, LED  
Cabin sun visor  
Heated penumatic seat  
Switch command ISO / SAE  
Telematics systems predisposition

## FRAME

2 or 4-steering wheels  
Steering direction inversion (4 steer wheels only)  
Rear blade (standard)  
Front blade and rear stabiliser  
Rubber protective pads under stabilisers  
Clamshell grab support  
Mudguards

## HEAVY COUNTERWEIGHT +450 KG (992 lb)

## ENGINE

Diesel Particulate Filter, DPF (standard in Europe)  
Automatic engine idle shutdown  
Electric diesel refueling pump with automatic stop  
Anti-theft device - electronic immobilizer with 6 keys

## AUXILIARY LINES

Additional auxiliary line  
Additional proportional auxiliary line  
Auxiliary line (deviation of bucket cilinder)  
Hammer return line

## ANTIDROP SAFETY VALVES

2 safety valves on adjustable boom (standard)  
Safety valves on boom, adjustable boom, dipperstick  
Safety valves on boom, adjustable boom, dipperstick, bucket

## QUICK COUPLER

Mecalac CONNECT hydraulic quick coupler - without hook (standard)  
Mecalac CONNECT hydraulic quick coupler - with hook  
Device for the Direct Coupling of tools on dipperstick ("pin-on") with pins, in-cab switch and hydraulic lines for quick couplers

## BOOM AND STICK

Mecalac versatile boom  
Two-piece boom (standard)  
Offset two-piece boom

## LUBRICATION

Standard manual greasing: single point for turret and first boom (standard)  
Centralized, manual lubrication for turret and boom/stick (except pins between connecting rod and quick coupling system)  
Centralized, automatic lubrication for turret and boom/stick

## OIL CHOICES

Hydraulic oil Total (ISO 46) (standard)  
Hydraulic oil Panolin (HLP 46)  
Hydraulic organic oil Total (BIOHYDRAN TMP 46)  
Hydraulic oil for cold weather (ISO 32)  
Hydraulic oil for hot weather (ISO 68)  
Hydraulic oil for very hot weather (ISO 100)



**15MWR**

# MECALAC EXCLUSIVE ACCESSORIES



## DIGGING BUCKETS

TYPE	WIDTH mm (in)	number of teeth	VOLUME l (yd <sup>3</sup> )	WEIGHT kg (lb)
DIGGING BUCKET with teeth	450 (1'6")	3	235 (0.31)	319 (700)
	500 (1'8")	3	270 (0.35)	331 (730)
	600 (2')	3	335 (0.44)	358 (790)
	850 (2'9")	4	515 (0.67)	434 (960)
	1000 (3'3")	4	625 (0.82)	485 (1070)
	1200 (3'11")	5	770 (1)	551 (1215)
DIGGING BUCKET without teeth	450 (1'6")	-	235 (0.31)	295 (650)
	500 (1'8")	-	270 (0.35)	306 (675)
	600 (2')	-	335 (0.44)	333 (735)
	850 (2'9")	-	515 (0.67)	401 (885)
	1000 (3'3")	-	625 (0.82)	452 (1,000)
	1200 (3'11")	-	770 (1)	510 (1,125)

## NARROW BUCKET

TYPE	WIDTH mm (in)	number of teeth	VOLUME l (yd <sup>3</sup> )	WEIGHT kg (lb)
NARROW BUCKET	300 (1')	2	95 (0.12)	275 (610)

## LOADER BUCKETS

TYPE	WIDTH mm (in)	number of teeth	VOLUME l (yd <sup>3</sup> )	WEIGHT kg (lb)
LOADER BUCKETS with teeth	2520 (8'3")	7	1000 (1.31)	614 (1,355)
LOADER BUCKETS without teeth	2520 (8'3")	-	1000 (1.31)	591 (1,300)

## 4X1 BUCKETS

TYPE	WIDTH mm (in)	number of teeth	VOLUME l (yd <sup>3</sup> )	WEIGHT kg (lb)
4X1 BUCKET with teeth	2520 (8'3")	7	750 (0.98)	792 (1,746)
PROTECTION 4X1 BUCKET with teeth	-	-	-	14 (30)
4X1 BUCKET without teeth	2520 (8'3")	-	750 (0.98)	769 (1,695)
PROTECTION 4X1 BUCKET without teeth	-	-	-	5 (11)
BOLTED COUNTERBLADE – 7 boreholes - center-to-center borehole distance 380 mm (1'25")	2520 (8'3")	-	-	71 (160)
KIT DE RACCORDEMENT	-	-	-	8 (18)

## PALLET FORK

TYPE	Specifications	WEIGHT kg (lb)
PALLET FORK	to be used with 4 safety valves	410 (905)
KIT - Blade-mounted Pallet fork		8 (17.6)

## DITCHING BUCKET

TYPE	Specifications	WIDTH mm (in)	VOLUME l (yd <sup>3</sup> )	WEIGHT kg (lb)
DITCHING BUCKET 1 COUPLING		2000 (6'7")	590 (0.77)	509 (1,120)
BOLTED COUNTER BLADE - Jagged	borehole center-to-center distance 185 mm (0'61")	2000 (6'7")	-	38 (85)
BOLTED COUNTER BLADE	borehole center-to-center distance 185 mm (0'61")	2000 (6'7")	-	57 (125)

## HANDLING PLATE

TYPE	Specifications	WEIGHT kg (lb)
HANDLING PLATE with hook	to be used with 3 safety valves	122 (270)

## HANDLING JIB

TYPE	Specifications	WEIGHT kg (lb)
HANDLING JIB	length 4100 mm (13'5"), lifting capacity 500 Kg (1,100 lb) to be used with 4 safety valves	177 (390)

## CLAMSHELL BUCKET SUPPORT

TYPE	Specifications	WEIGHT kg (lb)
CLAMSHELL BUCKET SUPPORT	-	124 (275)

## RIPPER TOOTH

TYPE	Specifications	WEIGHT kg (lb)
RIPPER TOOTH	-	293 (650)

## HAMMER PLATE

TYPE	Specifications	WEIGHT kg (lb)
HAMMER PLATE no boreholes	-	139 (305)
HAMMER PLATE with boreholes	contact your dealer	136 (300)

## TECHNICAL DATA

WEIGHT		DATA
In running order, with blade, with 75 kg operator, fuel tank full, twin tires with spacing ring, without optional equipment, with digging bucket 1000 mm		14218 kg (31,345 lbs)
In running order, with blade and stabilisers, with 75 kg operator, fuel tank full, twin tires with spacing ring, two-piece boom with offset, heavy counterweight, with digging bucket 1000 mm		15458 kg (34,079 lbs)
ENGINE		
Turbo charged engine with intercooler, EGR valve, catalytic converter (DOC) and Selective Catalytic Reduction (SCR) systems, complying with emissions standards		EU Stage V U.S. EPA Tier 4 Final*
Diesel 4 in-line cylinders		DEUTZ TCD 3.6 L4
Horsepower (DIN 70020) and Engine speed		100 kW (136hp - 134 imperial hp) at 2300 rpm
Max. torque		500 N.m at 1600 rpm (370 ft.lbf at 1600 rpm)
Cubic capacity		3621 cm <sup>3</sup> (221 in <sup>3</sup> )
Cooling		water
Air filterdry, cartridge (with clogging indicator in the cabin)		•
Fuel consumption (depending on operating conditions)		8 at 14 l/h
Sound power level (LWA)		101 dB(A)
Fuel tank capacity		220 l (58.1 gal)
ELECTRICAL SYSTEM		
Voltage		12 V
Batteries		1 x 95 Ah/800 A
Alternator		120 A
Starter		4 kW
Electric sockets sealed		•
UNDERCARRIAGE		
Rigid		•
Internal turning radius		•
- 4 steered wheels (optional)		1.93 m (6ft 4in)
- 2 steered wheels		4.44 m (14ft 7in)
Outside turning radius		•
- 4 steered wheels (optional)		4.44 m (14ft 7in)
- 2 steered wheels		7.36 m (24ft 2in)
Blade fitted on a parallelogram:		•
- lift height above ground		426 mm (1ft 5in)
- max. blade depth below ground		150 mm (6in)
Stabilisers controlled independently or in pairs		•
TRANSMISSION		
Open-circuit hydrostatic transmission		•
Driving direction inversion on joystick		•
Hydraulic motor coupled to a 2-speed ZF gearbox		Type "Powershift"
Continuously variable transmission rate over the BF: from 0 to 35 km/h whole speed range of the machine		from 0 to 35 km/h (from 0 to 21 mph)
"Cruise Control" and "Speed Control"		•
Max. traction force		8300 daN (18,660 lbf)
Max. pressure		350 bar (5,080 psi)
Pump flow-rate		160 l/min
Hydraulic engine		107 cm <sup>3</sup> (6.5 in <sup>3</sup> )

\*Depending on your Local Legislation - Environmental Protection Agency (EPA)

**NOTE**  
 METRIC MEASUREMENTS ARE THE CRITICAL VALUES  
 • 1 Litre = 0.26417 US Liquid Gallons  
 • 1 Litre = 0.21997 Imperial Liquid Gallons

## TECHNICAL DATA

### AXLES AND WHEELS DATA

4-wheel drive	•
Rigid drive axle on the rear	steering as an option
Drive axl over front chassis oscillates to +/-10°; oscillation block involves 2 hydraulic cylinders	steering as standard

### BRAKES

Double circuit central braking system	•
Oil-immersed multi-disk brakes on each axle	•

### TURRET

Full rotation 360°	•
Driven by internal crown slewing wheel	•
Swivel with hydraulic motor with brake	•
Rotation speed	10 rpm
Rotation torque	3800 daNm (28,000 ft.lbf)
Hydraulic engine	1260 cm <sup>3</sup> (77 in <sup>3</sup> )
Max. pressure	260 bar (3,800 psi)
Shock absorber for progressive turret rotation, start and stop anks, capacity	•

### CAB

Extremely comfortable panoramic cab without frame on the rear left side	ROPS and FOPS
Monocoque cab fastened to 4 spring posts	•
Front windshield partially or fully removable	under the cab roof
Sliding door	•
Opening door window	•
Position adjustable, seat adapts to the shape of the operator	seat adjustable in both height and width with seatbelt
Controls integrated into consoles located on either side of the seat and adjustable relative to the seat	•
Water heating system compliant with ISO 10263	high flow fan, high capacity for demisting and defrosting
Controls assisted by ergonomic, proportional control levers	•
7" color SCREEN combining safety and monitoring information of the machine functions	•
Fuel levels and coolant temperature indicated on the dashboard	•
Front working light, LED	•
Side and rear cameras	•
Rear storage area	refrigerated

### BOOM AND STICK

Mecalac variable range kinematics consisting of 4 parts: boom, adjustable boom, offset boom and dipperstick	enabling a angle of 140°
Standard right and left offset with a hydraulic cylinder	2.30 m (7ft 7in)/machine axis (with multipurpose Mecalac equipment)
End bearings equipped with sealing rings and greasing via the rings	•
Boom cylinders with end of travel shock absorbers	•
CONNECT quick coupler	•

### HYDRAULIC SYSTEM DATA

Variable displacement pump	maximum 130 cm <sup>3</sup> (max. 8 in <sup>3</sup> )
Maximum flow rate	270 l/min
Maximum working pressure	350 bar (5,080 psi)
Proportional Load Sensing with individual balancing of each element: boom, adjustable boom, dipper stick, bucket and ancillary	•
Proportionality of functions always achieved irrespective of the pressure level of each element: "flow sharing"	•
Anti-cavitation overpressure relief valve in each element	•
Hydraulically-assisted proportional function controls using joystick or foot pedals supplied at low pressure with emergency accumulator	•
Associated functions controlled by solenoid-operated valves	•
Auxiliary circuit, high flow (work tools)	standard
- Max. flow rate	180 l
- Adjustable flow rate to the monitor	•
- Proportional function	•
Hydraulic oil	122 l
Hydraulic circuit capacity	240 l

### OPERATING MODES

<b>WORKING MODE</b>
<ul style="list-style-type: none"> <li>• Turret rotation and dipperstick control with the left control lever</li> <li>• Bucket and intermediate boom or boom control with the right control lever</li> <li>• Travelling control using foot pedals</li> <li>• Operating the excavator in ISO mode</li> <li>• Immediate use of auto-idle function</li> <li>• Display of engine speed (rpm)</li> <li>• Screen display in Working Mode</li> </ul>

<b>DRIVING MODE</b>
<ul style="list-style-type: none"> <li>• Deactivation of the manual engine speed control. (The engine speed varies depending on how far the travel pedal is depressed)</li> <li>• Turning on road headlights</li> <li>• Turning on rotating beacon</li> <li>• Locking of machine hydraulic functions (Boom and stick, slewing, outriggers)</li> <li>• Deactivation of oscillation lock (only if oscillation lock selector is on AUTO) and is not activated via the right joystick</li> <li>• Deactivation of the travel alarm</li> <li>• Deactivation of the overload alarm</li> <li>• Display of speed in km/h</li> <li>• Deactivation of idle function via keypad and joystick</li> <li>• Speed controller</li> <li>• Screen display in Road Mode</li> </ul>

<b>PARKING MODE</b>
<ul style="list-style-type: none"> <li>• Engage parking brake</li> <li>• Turn the transmission into Neutral</li> <li>• Deactivation of the accelerator pedal</li> <li>• Set engine rpm into idle</li> <li>• Lock hydraulic and electrical controls</li> <li>• Screen display in Economy Mode</li> <li>• Lock oscillating axle</li> </ul>

<b>NOTE</b>
METRIC MEASUREMENTS ARE THE CRITICAL VALUES
<ul style="list-style-type: none"> <li>• 1 Litre = 0.26417 US Liquid Gallons</li> <li>• 1 Litre = 0.21997 Imperial Liquid Gallons</li> </ul>

## TECHNICAL DATA

### COMMON TO ALL BOOM KINEMATICS

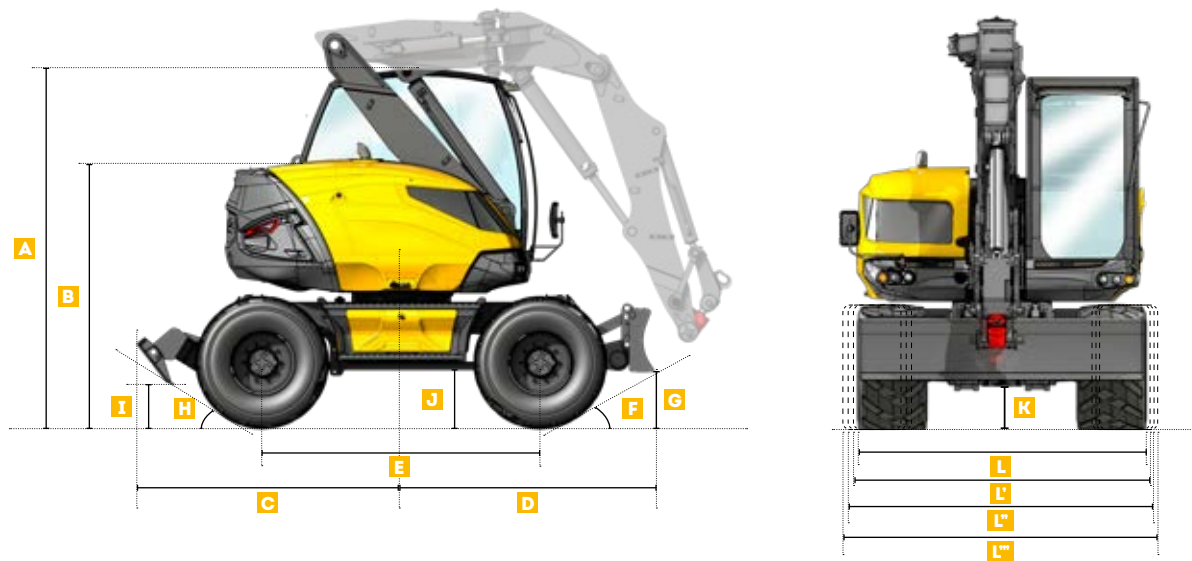

MACHINE DIMENSIONS	COMMON TO ALL BOOM KINEMATICS
<b>A</b> Cab height (without boom height)	3127 mm (10'3")
<b>B</b> Hood top height	2325 mm (7'8")
<b>C</b> Overhang of lower frame on stabilisers side	2328 mm (7'8")
<b>D</b> Overhang of lower frame on blade side	2241 mm (7'4")
<b>E</b> Wheelbase	2450 mm (8')
<b>F</b> Blade crossing angle	29°
<b>G</b> Height of blade raised	437 mm (1'5")
<b>H</b> Stabilisers crossing angle	32°
<b>I</b> Height of stabilisers raised	347 mm (1'2")
<b>J</b> Ground clearance at axle	454 mm (1'6")
<b>K</b> Ground clearance at gearbox	350 mm (1'2")
<b>L</b> Width with 18-19.5 tires	2390 mm (7'10")
<b>L'</b> Width with 10-20 twin tires	2520 mm (8'3")
<b>L''</b> Width with 600/40 tires	2520 mm (8'3")
<b>L'''</b> Width with Caliber tires	2580 mm (8'6")

## TECHNICAL DATA

### MECALAC VERSATILE BOOM

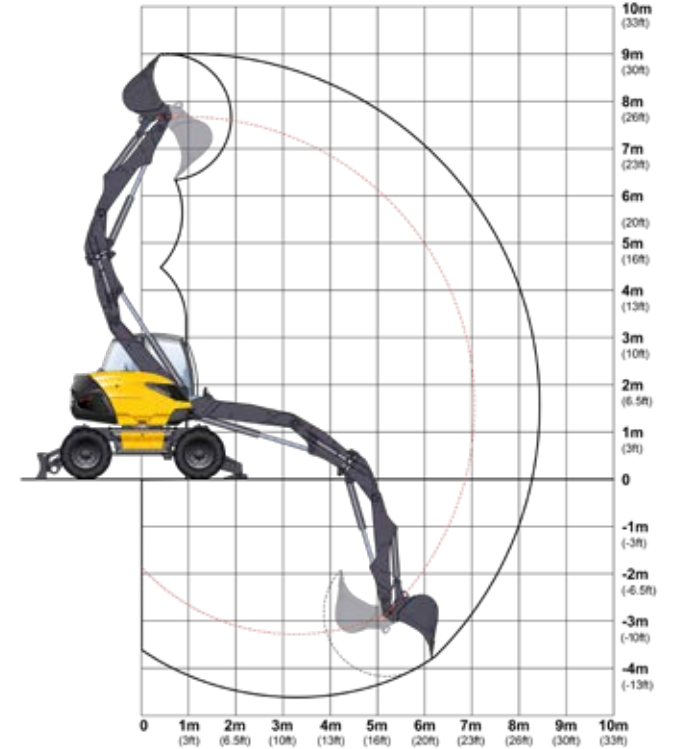
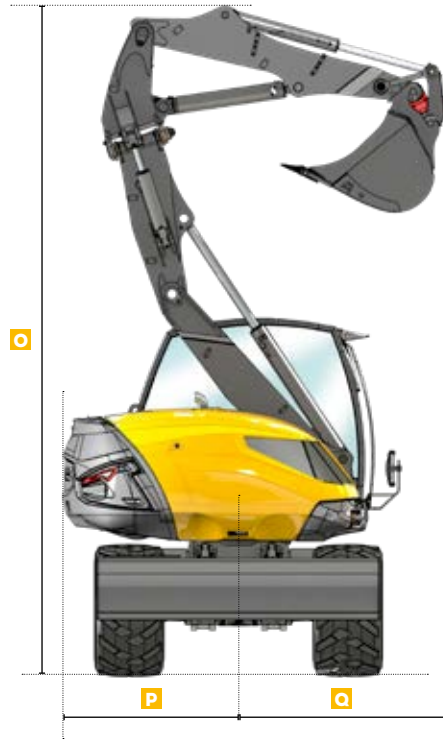

#### MACHINE DIMENSIONS

MACHINE DIMENSIONS		MECALAC VERSATILE BOOM	
<b>M</b>	Overall length with boom and stick	5200 mm (17'1")	
<b>N</b>	Overall height of structures	3660 mm (12')	
<b>O</b>	Height in swing position	5815 mm (19'1")	
<b>P</b>	Tail swing radius	1570 mm (5'2")	
<b>Q</b>	Minimal front radius	1845 mm (6'1")	

#### PERFORMANCE DIGGING BUCKET

Break-out force	8170 daN (18,370 lbf)
Penetration/Tear-out force	5500 daN (12,360 lbf)
Maximum reach	8300 mm (27'3")
Maximum digging depth	4550 mm (14'11")

#### LIFTING FORCE WITH LOADING HOOK - WITH BLADE AND STABILISERS ON GROUND

All the weights are given in kg (lb).

	FRONT		SIDE		FRONT		SIDE	
	3M (9'10")	4.5M (14'9")	4.5M (14'9")	6M (19'8")	6M (19'8")	3M (9'10")	4.5M (14'9")	
<b>3M (9'10")</b>	8000 (17,640)	8000 (17,640)	6600 (14,550)	4400 (9,700)	4600 (10,140)	2200 (4,850)		
<b>0M</b>	8000 (17,640)	8000 (17,640)	8000 (17,640)	3400 (7,500)	5200 (11,460)	2000 (4,400)		
<b>-1.5M (4'11")</b>	8000 (17,640)	8000 (17,640)	8000 (17,640)	3300 (7,280)	3900 (8,600)	1900 (4,190)		

#### LIFTING FORCE WITH LOADING HOOK - ON WHEELS

All the weights are given in kg (lb).

	FRONT		SIDE		FRONT		SIDE	
	3M (9'10")	4.5M (14'9")	4.5M (14'9")	6M (19'8")	6M (19'8")	3M (9'10")	4.5M (14'9")	
<b>3M (9'10")</b>	8000 (17,640)	6500 (14,330)	4600 (10,140)	3400 (7,500)	2400 (5,290)	1700 (3,750)		
<b>0M</b>	8000 (17,640)	6000 (13,230)	3700 (8,160)	2600 (5,730)	2200 (4,850)	1500 (3,300)		
<b>-1.5M (4'11")</b>	8000 (17,640)	4500 (9,920)	3700 (8,160)	2300 (5,070)	2100 (4,630)	1400 (3,090)		

#### WORKING CONDITIONS AT LIFTING HOOK

- On horizontal, compact ground
- Equipment used without offset
- Oscillation axle blocked
- Without tools (bucket, shovel...) with handling plate and loading hook of 8 T
- Wheels 18-19.5
- 75% of the tipping load or 87% of the hydraulic capacity
- Maximum values determined for optimal position of boom and cylinders

# 15MWR

## TECHNICAL DATA

### TWO-PIECE BOOM

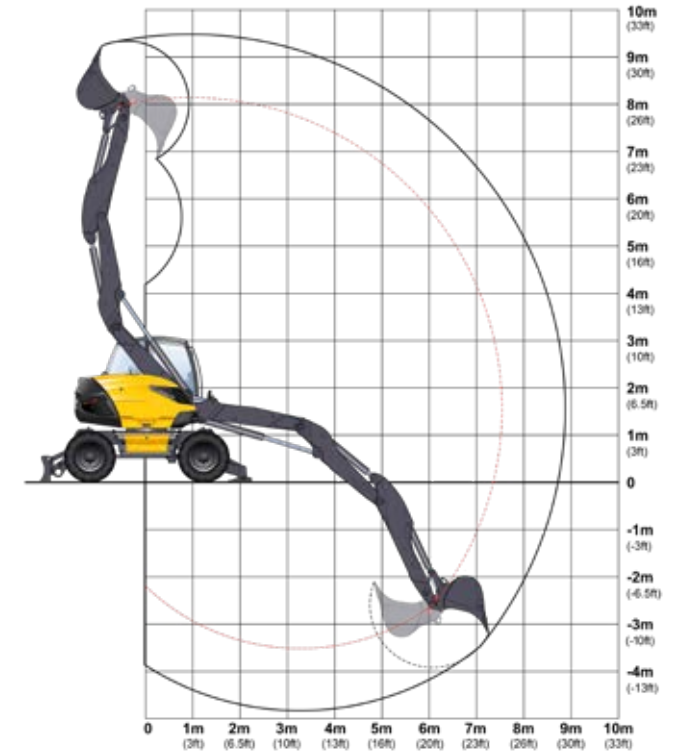
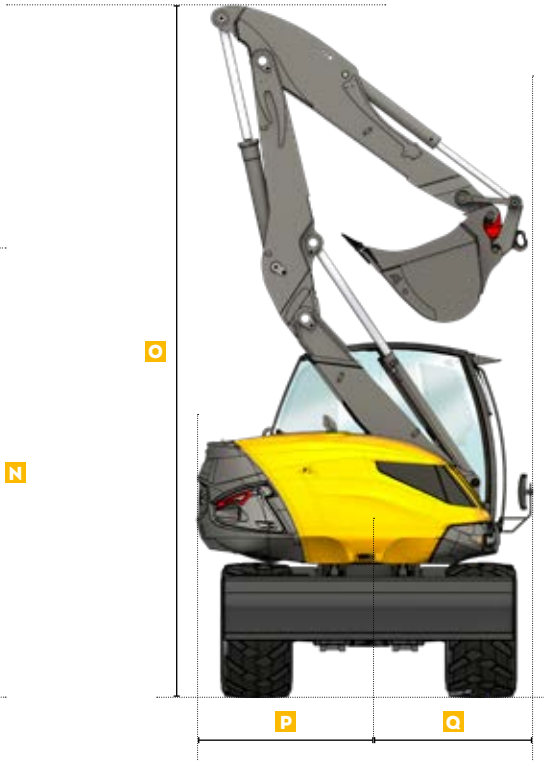

MACHINE DIMENSIONS		TWO-PIECE BOOM	
<b>M</b>	Overall length with boom and stick	5200 mm (17'1")	
<b>N</b>	Overall height of structures	3735 mm (12'3")	
<b>O</b>	Height in swing position	6130 mm (20'1")	
<b>P</b>	Tail swing radius	1570 mm (5'2")	
<b>Q</b>	Minimal front radius	1420 mm (4'9")	

PERFORMANCE DIGGING BUCKET	
Break-out force	8170 daN (18,370 lbf)
Penetration/Tear-out force	6200 daN (13,940 lbf)
Maximum reach	8800 mm (28'10")
Maximum digging depth	4800 mm (15'9")

#### LIFTING FORCE WITH LOADING HOOK - WITH BLADE AND STABILISERS ON GROUND

All the weights are given in kg (lb).

	FRONT		SIDE		FRONT		SIDE	
	3M(9'10")	4.5M(14'9")	6M(19'8")	7.5M(24'7")	3M(9'10")	4.5M(14'9")	6M(19'8")	7.5M(24'7")
<b>3M(9'10")</b>	8000 (17,640)	8000 (17,640)	6500 (14,330)	4400 (9,700)	4600 (10,140)	2300 (5,070)	3300 (7,280)	1400 (3,090)
<b>0M</b>	8000 (17,640)	8000 (17,640)	8000 (17,640)	3500 (7,720)	5400 (11,900)	2000 (4,400)	2800 (6,170)	1300 (2,870)
<b>-1.5M(4'11")</b>	8000 (17,640)	8000 (17,640)	8000 (17,640)	3200 (7,060)	4100 (9,040)	1900 (4,190)	-	-

#### LIFTING FORCE WITH LOADING HOOK - ON WHEELS

All the weights are given in kg (lb).

	FRONT		SIDE		FRONT		SIDE	
	3M(9'10")	4.5M(14'9")	6M(19'8")	7.5M(24'7")	3M(9'10")	4.5M(14'9")	6M(19'8")	7.5M(24'7")
<b>3M(9'10")</b>	8000 (17,640)	6600 (14,550)	4700 (10,360)	3500 (7,720)	2400 (5,290)	1700 (3,750)	1500 (3,300)	1000 (2,200)
<b>0M</b>	8000 (17,640)	6000 (13,230)	3800 (8,380)	2700 (5,950)	2200 (4,850)	1500 (3,300)	1400 (3,090)	900 (1,980)
<b>-1.5M(4'11")</b>	8000 (17,640)	4700 (10,360)	3600 (7,940)	2400 (5,290)	2100 (4,630)	1400 (3,090)	-	-

#### WORKING CONDITIONS AT LIFTING HOOK

- On horizontal, compact ground
- Oscillation axle blocked
- Without tools (bucket, shovel...) with handling plate and loading hook of 8 T
- Wheels 18-19.5
- 75% of the tipping load or 87% of the hydraulic capacity
- Maximum values determined for optimal position of boom and cylinders

## TECHNICAL DATA

### OFFSET TWO-PIECE BOOM

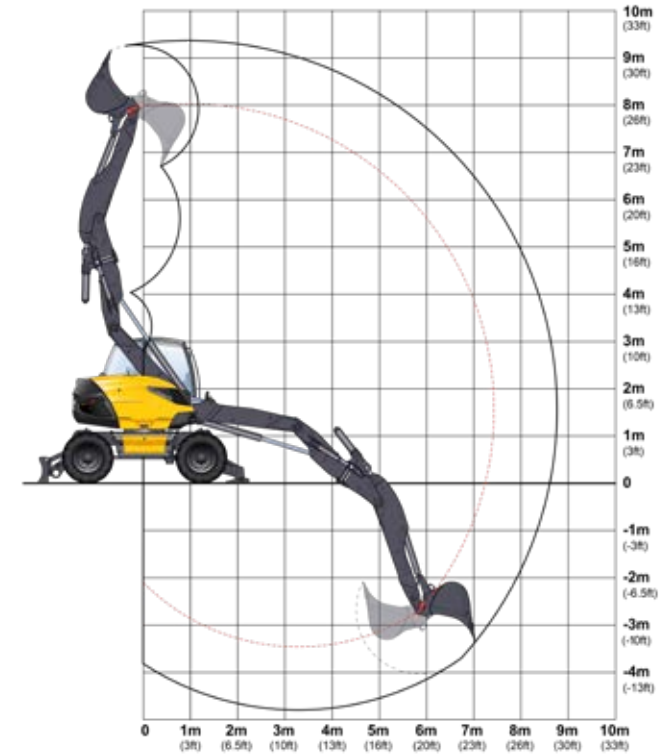
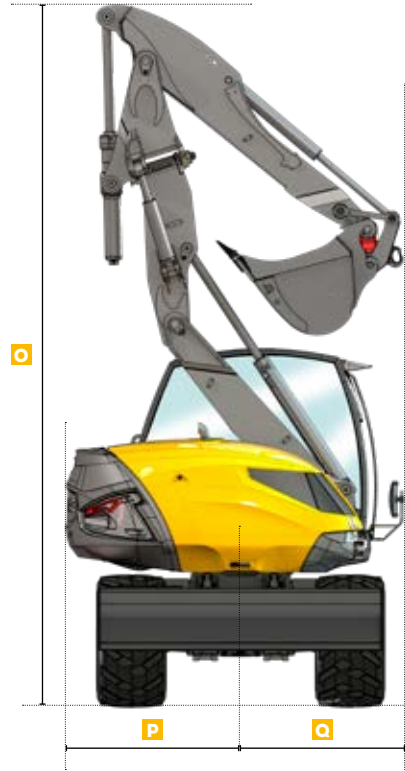

#### MACHINE DIMENSIONS

	OFFSET TWO-PIECE BOOM	
<b>M</b> Overall length with boom and stick	5200 mm (17'1")	
<b>N</b> Overall height of structures	3786 mm (12'5")	
<b>O</b> Height in swing position	6130 mm (20'1")	
<b>P</b> Tail swing radius	1570 mm (5'2")	
<b>Q</b> Minimal front radius	1420 mm (4'9")	

#### PERFORMANCE DIGGING BUCKET

Break-out force	8170 daN (18,370 lbf)
Penetration/Tear-out force	6200 daN (13,940 lbf)
Maximum reach	8700 mm (28'7")
Maximum digging depth	4700 mm (15'9")

#### LIFTING FORCE WITH LOADING HOOK - WITH BLADE AND STABILISERS ON GROUND

All the weights are given in kg (lb).

	FRONT		SIDE		FRONT		SIDE	
	3M(9'10")	4.5M(14'9")	6M(19'8")	7.5M(24'7")	3M(9'10")	4.5M(14'9")	6M(19'8")	7.5M(24'7")
<b>3M(9'10")</b>	8000 (17,640)	8000 (17,640)	6400 (14,110)	4400 (9,700)	4500 (9,920)	2500 (5,510)	2900 (6,390)	1300 (2,870)
<b>OM</b>	8000 (17,640)	8000 (17,640)	8000 (17,640)	3400 (7,500)	5200 (11,460)	1900 (4,190)	2700 (5,950)	1200 (2,650)
<b>-1.5M(4'11")</b>	8000 (17,640)	8000 (17,640)	8000 (17,640)	3000 (6,600)	4000 (8,820)	1800 (3,970)	-	-

#### LIFTING FORCE WITH LOADING HOOK - ON WHEELS

All the weights are given in kg (lb).

	FRONT		SIDE		FRONT		SIDE	
	3M(9'10")	4.5M(14'9")	6M(19'8")	7.5M(24'7")	3M(9'10")	4.5M(14'9")	6M(19'8")	7.5M(24'7")
<b>3M(9'10")</b>	8000 (17,640)	6500 (14,330)	4700 (10,360)	3400 (7,500)	2500 (5,510)	1700 (3,750)	1400 (3,090)	900 (1,980)
<b>OM</b>	8000 (17,640)	5900 (13,000)	3600 (7,940)	2500 (5,510)	2100 (4,630)	1400 (3,090)	1300 (2,870)	800 (1,760)
<b>-1.5M(4'11")</b>	8000 (17,640)	4400 (9,700)	3400 (7,500)	2200 (4,850)	2000 (4,400)	1300 (2,870)	-	-

#### WORKING CONDITIONS AT LIFTING HOOK

- On horizontal, compact ground
- Equipment used without offset
- Oscillation axle blocked
- Without tools (bucket, shovel...) with handling plate and loading hook of 8 T
- Wheels 18-19.5
- 75% of the tipping load or 87% of the hydraulic capacity
- Maximum values determined for optimal position of boom and cylinders

**MECALAC FRANCE S.A.S.**  
2, avenue du Pré de Challes  
Parc des Glaisins – CS 40230  
Annecy-le-Vieux  
FR - 74942 Annecy Cedex  
Tel. +33 (0)4 50 64 01 63

**MECALAC BAUMASCHINEN  
GMBH**  
Am Friedrichsbrunnen  
D-24782 Büdelsdorf  
Tel. +49 (0)43 31/3 51-319

**MECALAC CONSTRUCTION  
EQUIPMENT UK LTD**  
Central Boulevard,  
ProLogis Park  
Coventry, CV6 4BX, UK  
Tél. +44 (0)24 7633 9539

**MECALAC İŞ MAKİNELERİ  
SAN VE TIC. LTD. ŞTİ.**  
Ege Serbest Bölgesi Nilüfer 1 Sok. No: 34  
35410, Gaziemir  
İzmir - Türkiye  
Tel. +90 232 220 11 15



[WWW.MECALAC.COM](http://WWW.MECALAC.COM)

Materials and specifications are subject to change without notice. Actual products may differ from photos. Featured machines in photos may include additional equipment. See your Mecalac dealer for available options.  
2019 Mecalac © All rights reserved.

**MK385/EN-11/19 15MWR** Design Les Alchimistes Photo credits Sémaphore - Istockphoto - Fotolia Printed by Kalistene **Non-binding document**